

# ALBANY PUMP CO. LTD.

420 Harry Walker pkwy, Newmarket, Ontario Canada, L3Y8P5.  
sales@albanyump.com / www.albanyump.com

## ALBANY DBS DUAL BASKET STRAINER & FILTER



Available with Mesh Screens for Strainer  
Available with Micron Elements for Filter

### SERVICE RECOMMENDATIONS

These strainers are used to remove foreign matter from pipe lines and provide inexpensive protection to pumps, meters, valves, etc. The DBS Series can be specified for Strainer applications from 20 mesh to 200 mesh, and can be specified for Filter applications to 5 Micron.

### FEATURES

These strainers have been designed for applications where easy maintenance & large capacity straining are needed. Service time is minimal because the cover is secured with quick opening, non-yoke type knobs. Both the cover & the basket use O-ring seals, eliminating the need to replace gaskets each time the strainer is serviced. This, combined with the machined basket seat, eliminates particle bypass. With the appropriate wire mesh lining, these models can be used to strain particles as small as five microns.

### CONSTRUCTION

Cast cover and body. All sizes feature an O-ring cover seal. Baskets and O-ring are sealed in machined seats. Quick release knobs are insert molded with metal threads. An NPT connection is provided. Coatings are available on application. Standard strainers basket 304 ss. Filter elements are available in 5, 10, 25, and 40 micron. Viton O-ring is standard.

**CAPACITY:** Minimum 6 to 1 open area ratio.

**PRESSURE RATING:** 150 PSI

**RATING:** Shell test pressure = 1.5 times working pressure.

**CASING TEMPERATURE RATING:** + 2000°F°F



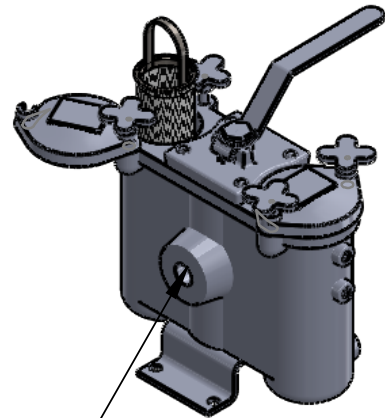
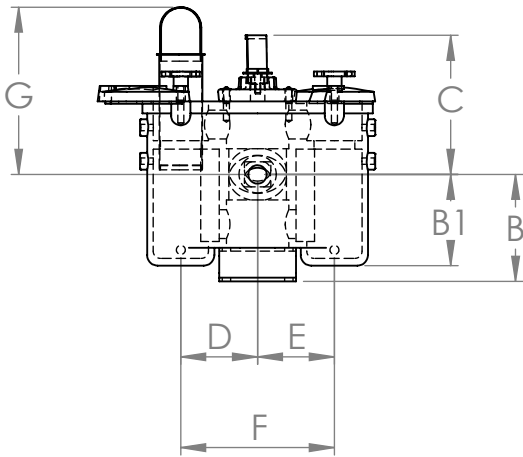
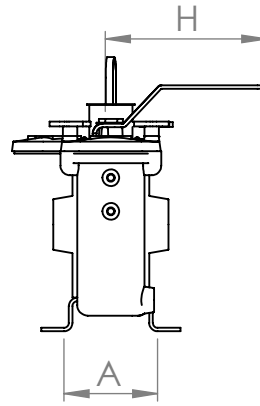
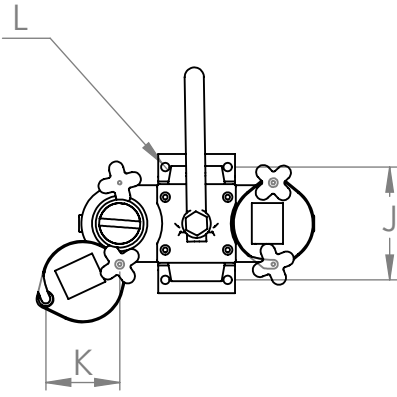

Pipe Size



Pipe Size	Weight	A	B	B1	C	D	E	F	G	H	I	J	K	L
1/2"	36lbs	4.5"	5.25"	3.75"	6.50"	8.00"	6.00"	7.25"	8.75"	8.25"	2.125"	6.00"	4.88"	21/64"
3/4"	36lbs	4.5"	5.25"	3.75"	6.50"	8.00"	6.00"	7.25"	8.75"	8.25"	2.125"	6.00"	4.88"	21/64"
1"	36 lbs	4.5"	5.25"	3.75"	6.50"	8.00"	6.00"	7.25"	8.75"	8.25"	2.125"	6.00"	4.88"	21/64"
1-1/4"	42 lbs	6.0"	6.00"	5.00"	7.25"	8.50"	6.13"	8.00"	11.75"	8.25"	3.25"	6.00"	4.88"	27/64"
1-1/2"	42 lbs	6.0"	6.00"	5.00"	7.25"	8.50"	6.13"	8.00"	11.75"	8.25"	3.25"	6.00"	4.88"	27/64"
2"		8.0"	N/A	6.25"	8.00"	11.00"	9.25"	12.00"	16.00"	9.50"	N/A	N/A	N/A	N/A

Copyright Albany Pump Co. Ltd. All rights reserved. This drawing and the information contained or depicted herein are the sole property of Albany Pump Co. Ltd. Copies are communicated to the recipient in strict confidence and may not be retransmitted, published, reproduced, copied or used in any manner, including as the basis for the manufacture or sale of any products, without the express prior written consent of Albany Pump Co. Ltd..